

SALES & ENGINEERING DATA

PD15X-XXX-XXX and PE15X-XXX-XXX 1-1/2" METALLIC DIAPHRAGM PUMP

RATIO SERIES:	1:1
FLUID P.S.I. RANGE:	20 - 120
RELEASED:	8-7-03
REVISED:	6-9-10
(REV. 09)	S-1281

DIMENSIONAL DATA

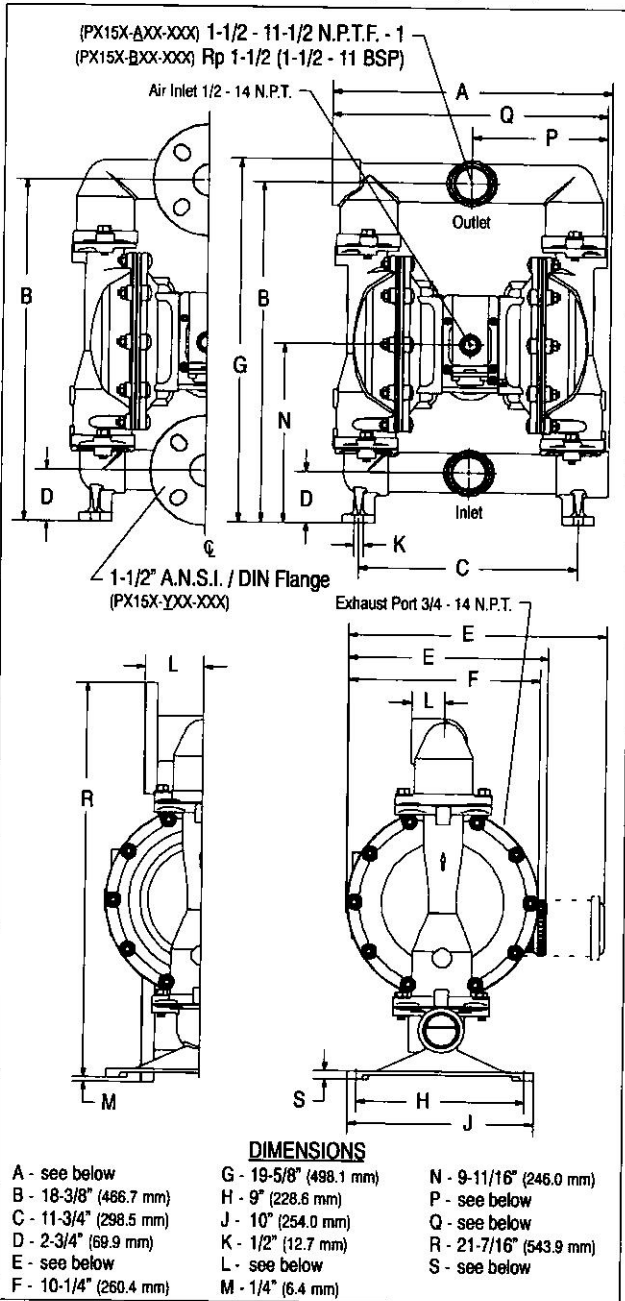

SPECIFICATIONS

CONSTRUCTION

Model Series	PD15X-XXX-XXX PE15X-XXX-XXX
Pump Type	Metallic, Air Operated, Double Diaphragm
Ratio	1:1
Material Inlet / Outlet (female)	
PX15X-AXX-XXX	1-1/2 - 11-1/2 N.P.T.F. - 1
PX15X-BXX-XXX	Rp 1-1/2 (1-1/2 - 11 BSP)
PX15X-YXX-XXX	1-1/2" A.N.S.I. / DIN Flange
Air Inlet (female)	1/2 - 14 N.P.T.
Air Exhaust (female)	3/4 - 14 N.P.T.
Weight	
PX15R-XAX-XXX	37.65 lbs (17.08 kgs)
PX15R-XCX-XXX	73.2 lbs (33.2 kgs)
PX15R-XHX-XXX	86.9 lbs (39.4 kgs)
PX15R-XSX-XXX	61.2 lbs (27.8 kgs)
	add 2.14 lbs (0.97 kg) for aluminum air motor section
	add 18.14 lbs (8.23 kg) for stainless steel air motor section
Air Section Service Kit	637389
Major Air Valve Assembly	637390-X
Fluid Section Service Kit	637375-XX

PX15X-XXX-X
637375 -
Diaphragm Material
Ball Material

EXAMPLE: Model # PD15S-ASS-SAA
Fluid Section Service Kit is 637375-AA

PERFORMANCE

Air Inlet Pressure Range	20 - 120 p.s.i. (1.4 - 8.3 bar)
Maximum Material Inlet Pressure	10 p.s.i. (0.69 bar)
Fluid Pressure Range	20 - 120 p.s.i. (1.4 - 8.3 bar)
Maximum Flow Rate (flooded inlet)	123 g.p.m. (465.6 l.p.m.)
Displacement / Cycle @ 100 p.s.i.	0.617 gal. (2.34 lit.)
Maximum Particle Size	1/4" dia. (6.4 mm)
Maximum Temperature Limits (diaphragm / ball / seal material)	
E.P.R. / EPDM	-60° to 280° F (-51° to 138° C)
Hytrek	-20° to 150° F (-29° to 66° C)
Nitrile	10° to 180° F (-12° to 82° C)
Polypropylene	35° to 150° F (2° to 66° C)
Santoprene	-40° to 225° F (-40° to 107° C)
PTFE	40° to 225° F (4° to 107° C)
Viton	-40° to 350° F (-40° to 177° C)
Noise Level @ 70 p.s.i. - 60 c.p.m.	82.8 db(A)①

① The pump sound pressure level has been updated to an Equivalent Continuous Sound Level (L_{Aeq}) to meet the intent of ANSI S1. 13-1971, CAGI-PNEUROP S5.1 using four microphone locations.

	"A"	"L"	"P"	"Q"	"S"	"E"
PX15X-XAX-XXX	14-7/8" (377.8 mm)	1-3/4" (44.5 mm)	7-7/32" (183.4 mm)	14-23/32" (373.9 mm)	1/2" (12.7 mm)	PX15A-XXX-XXX 14-1/32" (356.2 mm)
PX15X-XCX-XXX	14-5/8" (371.5 mm)	1-3/4" (44.5 mm)	7-3/16" (182.6 mm)	14-1/2" (368.3 mm)	1/4" (6.4 mm)	PX15R-XXX-XXX 11-3/32" (281.3 mm)
PX15X-XHX-XXX	14-9/16" (370.0 mm)	3-1/8" (79.4 mm)	7-3/16" (182.6 mm)	14-1/2" (368.3 mm)	1/4" (6.4 mm)	PX15S-XXX-XXX 13-7/8" (352.4 mm)
PX15X-ASX-XXX	14-25/32" (375.5 mm)	1-3/4" (44.5 mm)	7-9/32" (185.0 mm)	14-13/16" (375.5 mm)	15/32" (11.4 mm)	
PX15X-BSX-XXX	14-25/32" (375.5 mm)	1-3/4" (44.5 mm)	7-9/32" (185.0 mm)	14-13/16" (375.5 mm)	15/32" (11.4 mm)	
PX15X-YSX-XXX	14-9/16" (370.0 mm)	3-1/8" (79.4 mm)	7-9/32" (185.0 mm)	14-9/16" (370.0 mm)	15/32" (11.4 mm)	

INGERSOLL RAND COMPANY LTD

209 NORTH MAIN STREET - BRYAN, OHIO 43306

☎ (800) 495-0276 • FAX(800) 892-6276

www.ingersollrandproducts.com

© 2010

CCN 15198989

ARO Ingersoll Rand
Industrial Technologies

PERFORMANCE CURVES

